

DEXTER RESEARCH CENTER, INC.

Temperature Compensation of DC Radiometer

Engineering note: This Application Brief uses old technology and is therefore provided as a starting point only. We plan to revise this brief in the future.

The thin film thermopile detector like its forefather, the wire thermocouple, requires either a reference junction temperature measurement or a constant temperature sink for its reference junction. The later is usually difficult to implement in an instrument because of size and weight requirements. The detector reference junction temperature can be measured by attaching a temperature transducer to the detector case. Some of the transducers that have been used are:

1. Thermistor bead, e.g. Yellow Springs Instruments, YSI-44201
2. Signal diode, e.g. 1N4148
3. Integrated circuit, e.g. Analog Devices AD590

One characteristic common to these devices is that they require power to operate, and therefore, result in self heating. The instrument designer must exercise extreme caution not to upset the delicate thermal balance between the thermopile detector's active and reference junctions by introducing thermal transients from the temperature transducer's self heating. Keeping this caution in mind, we will proceed to design a temperature compensated DC radiometer.

There are three main tasks in implementing a temperature compensating network. These tasks are:

1. Attach the temperature transducer to sense the thermopile's reference junction.
2. Design a circuit to combine the detector voltage with the compensating voltage.
3. Scale the voltages to a fixed calibration scheme.

The predominate mode of heat transfer to and from the thermopile's reference junctions is through the TO-5 header leads and the header itself. These leads (with internal heatsink models and ST model detector) are thermally isolated from the TO-5 case by a glass to metal bond, which seals the leads to the header. Since our job is to measure reference junction temperature, between these leads is the ideal site to attach our temperature transducer. This transducer should be outside the TO-5 case. A short experiment will explain why. In typical radiometer applications, there are a few μW incident on the detector's active junctions from the object to be measured. However, the temperature transducer has an internal self dissipation of several hundred μW . These μW 's are received more efficiently by the detector because of the large solid angle $\sim 3\text{sr}$. In comparison, an $f/1$ optical system will have a solid angle of $\sim 0.63\text{sr}$, which is nearly a

Postal Mail: 7300 Huron River Dr.
Dexter, MI 48130 U.S.A.

Phone: 734-426-3921
Fax: 734-426-5090

Email: Sales@DexterResearch.com
Web: www.DexterResearch.com

factor of 5 less. The point is that device self heating causes a signal hundreds of times greater than the signal we are trying to detect. The proper attachment of a temperature transducer is shown in Fig. 1. The salient features are:

1. The device is thermally well coupled to the detector leads, and by lead conduction to the detector reference junctions.
2. The device is thermally coupled to the detector header, thereby damping thermal transients.
3. Device self heating is conducted away by the detector holder (not shown in Fig. 1).

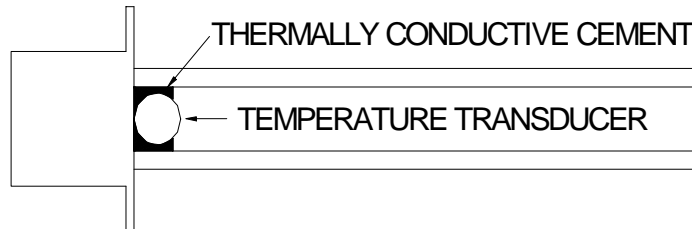

Fig. 1. Temperature Transducer Attached to Detector Leads.

The circuit design will be based on the YSI-44201 Thermistor. The basic principles are identical for the other devices, only the circuit details would be altered. Fig. 2 shows a circuit using a Thermistor bead B1 attached to a detector model 1M. A1 amplifies the detector voltage and R3 is used to calibrate the instrument. The voltage V_1 has the form

$$V_1 = k(T_t^4 - T_d^4) \quad (1)$$

Where k = systems constant which includes Detector Parameters (see equation for V_{det} on page 2 of Application Brief 1), optical system, and the gain of A1

T_t = absolute target temperature in Kelvin.

T_d = absolute detector reference junction temperature in Kelvin.

If the inputs to R7 and R8 are zero, then the output of A3 is

$$V_0 = - \frac{R_9}{R_3} K [T_t^4 - T_d^4] \quad \text{or} \quad V_0 = - \frac{R_9}{R_3} k T_t^4 + \frac{R_9}{R_3} k T_d^4 \quad (2)$$

From this result we see that a voltage equal to $\frac{R_9}{R_3} k T_d^4$ must be subtracted from V_0 to compensate for the detector reference junction temperature.

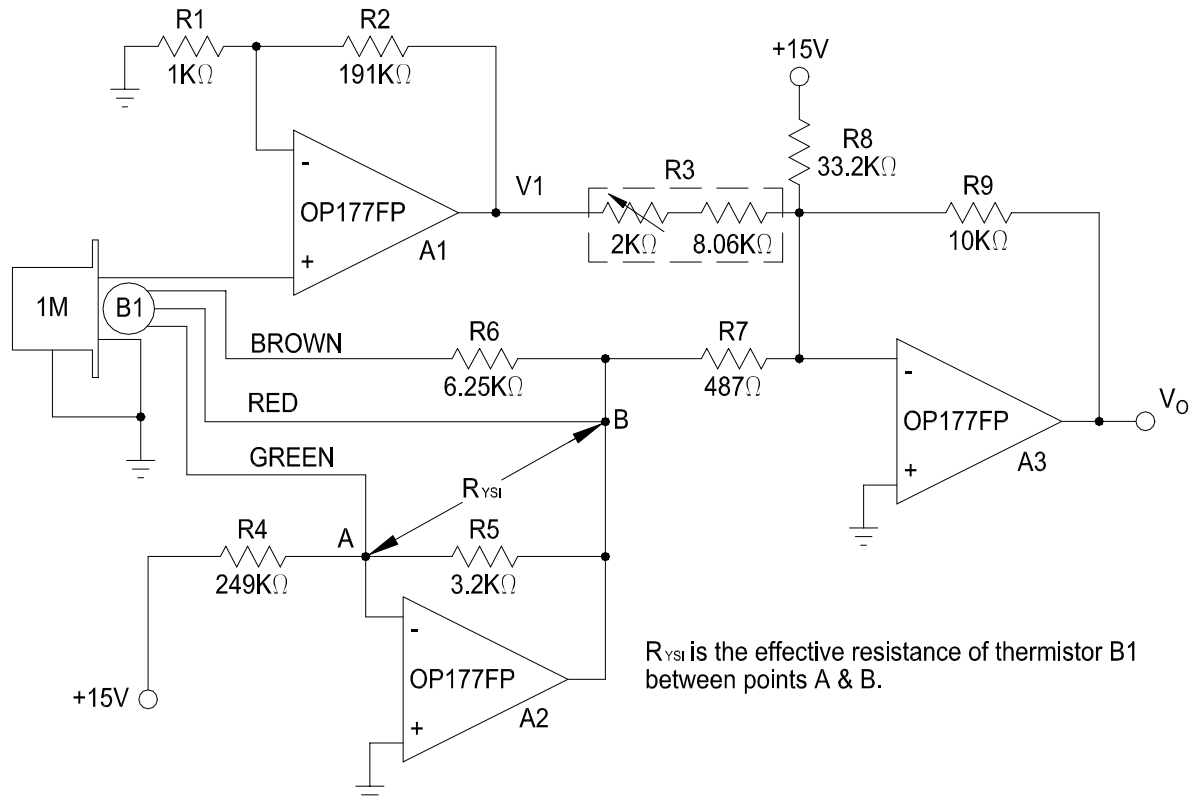

Fig. 2. Radiometer Circuit with Temperature Compensation.

The voltage from A2 is

$$V_T = -15 \frac{R_{YSI}}{R_4} \quad \text{or} \quad V_T = -\frac{15V}{R_4} (2768.23 - 17.115T_c) \quad (3)$$

Where $R_{YSI} = 2768.23 - 17.115T_c$, T_c = detector case temperature in °C, and the decimal numerical values are taken from the YSI-44201 data sheet with values for R_5 & R_6 as shown. This voltage, along with the detector voltage and reference voltage at the top of R_8 , are summed by A_3 . The final output voltage of A_3 is

$$V_0 = -\frac{R_9}{R_3} kT_t^4 + \left[\frac{R_9}{R_3} kT_d^4 - \frac{R_9 \cdot 15}{R_7 \cdot R_4} (-2768.23 + 17.115 T_c) - \frac{R_9 \cdot 15}{R_8} \right] \quad (4)$$

When the bracketed term is zero the radiometer is compensated and the voltage from A_3 is

$$V_0 \text{ (compensated)} = -\frac{R_9}{R_3} kT_t^4 \quad (5)$$

This result will be the basis of our calibration scheme.

In application brief 1, a simple radiometer was shown that had a temperature range from 0°C to 200°C. The result of that design is repeated here in Table 1.

Target Temperature (T_t)		Detector Voltage (V_{det})	Compensated Voltage (V_0)
K	°C	mV	mV
273	0	-1.62	5.18
298	25	0.46	7.35
323	50	3.14	10.01
373	100	10.71	18.04
473	200	38.14	46.64

Table 1. Un-amplified Detector Voltage for a Simple Radiometer w/ ambient temperature = 20°C.

For this design we will let a target temperature of 200°C give 10 volts at the output of A3. The gain of A1 can be calculated as $G = 10/0.04664 = 214.41$. Since detector responsivity will vary from detector to detector by $\pm 10\%$, we will approximate G with the gain of A1 and set, using available resistor values to approximate G, $R1 = 1K$ and $R2 = 191K$. Giving the gain of A1 as 192. The ratio of $R9/R3$ will be adjusted during instrument calibration to give the desired system gain to give an output of 10V a 200°C.

The next step is to determine the instrument constant, from equation 5 when $V_0 = 10V$ at $T_t = 473K$

$$\frac{R9}{R3} k = - \frac{10}{(473)^4} = -1.998 \times 10^{-10} V/K^4 \quad (6)$$

We will assume that the radiometer will be used in ambients from 0°C to 50°C. Using the previously determined instruments constant and ambient temperature range we can plot the required compensating voltage (fig. 3) in order to give an accurate output voltage proportional to the target temperature.

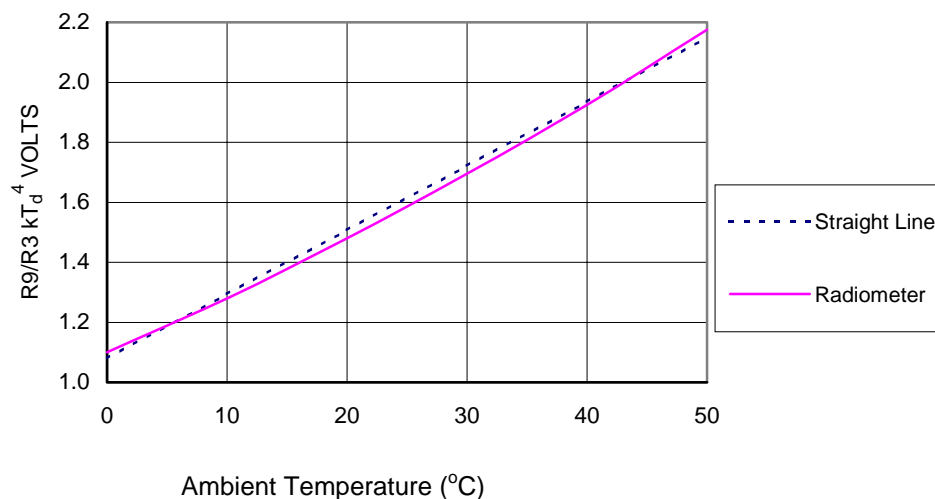

Fig. 3. Required Compensating Voltage $\frac{R9}{R3} k T_d^4$ from equation 4 versus ambient temperature with a Straight Line Fit.

DEXTER RESEARCH CENTER, INC.

The dashed line shows the linear voltage fit from the Thermistor (1.08V@0°C and 2.15V@50°C). For an equation of the form $V_c = mT_c + b$ we have

$$b = 1.08; m = (2.15 - 1.08)/50$$

or

$$V_c = .0214T_c + 1.08 \tag{7}$$

Equating like coefficients of the bracketed part of equation 4 and equation 7

$$\frac{-R_9 \cdot 15}{R_7 \cdot R_4} 17.115T_c = -0.0214T_c \tag{8}$$

To keep Thermistor self heating low let $R_4 = 249K\Omega$. Using equation 8 and solving using standard resistor values, let $R_9 = 10K\Omega$ which gives $R_7 = 482\Omega$. Selecting the closest 1% resistor we let $R_7 = 487\Omega$.

$$\frac{R_9 \cdot 15}{R_7 \cdot R_4} 2768.23 - 15 \frac{R_9}{R_8} = -1.08 \tag{9}$$

Solving equation 9 for R_8 we have $R_8 = 33.3K\Omega$. Again selecting the closest 1% resistor $R_8 = 33.2K\Omega$.

Summarizing: $R_9 = 10K\Omega$, $R_8 = 33.2K\Omega$, $R_7 = 487\Omega$ and $R_4 = 249K\Omega$. Substituting these values into the bracketed terms of equation 4 and using equation 6 we have

$$\Delta = - 1.998 \times 10^{-10} T_d^4 - 1.09376 - .02117T_c \tag{10}$$

Fig. 4 shows a plot of voltage error of equation 10.

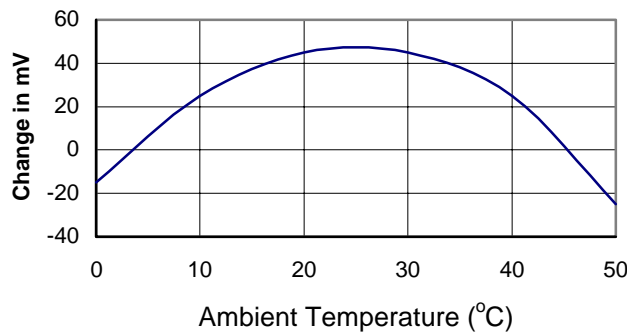

Fig. 4. Error in Compensating Voltage caused by Linear Fit of 4th Power law.

This application brief has shown in detail, one method of temperature compensating a DC thermopile radiometer. Simple circuitry and 1% resistors were used along with a bead thermistor. The basic principle described may be implemented using other temperature transducers.